

Aşağıdaki varlıkların adlarında "S - S" sesinin geçtiği resimlerin altındaki kutucuğu işaretleyiniz.

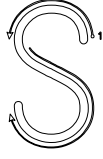
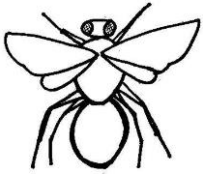

S S S S S S S S S S S

S S

S S

S S S S S S S S S

S

S

Sevgili öğrenciler, aşağıdaki heceleri tekrar tekrar okuyunuz. Oluşturulan kelimeleri örneklerdeki gibi karşılarındaki boşluklara yazarak okuyunuz.

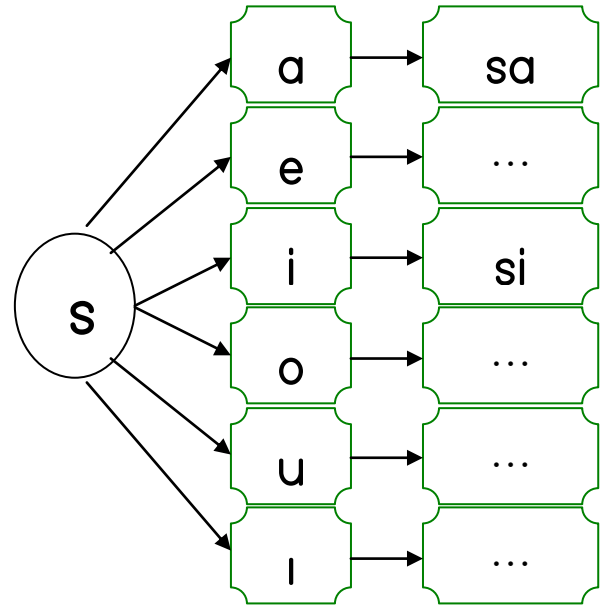
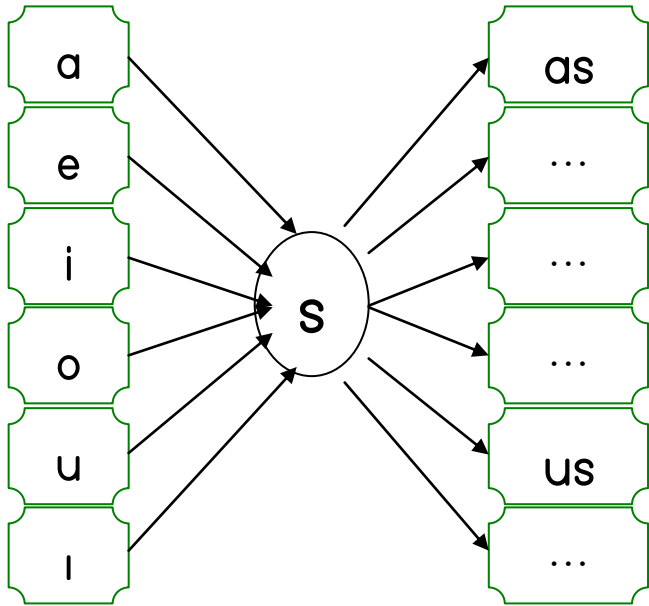

Oluşan kelimeleri okuyarak karşlarına yazınız.

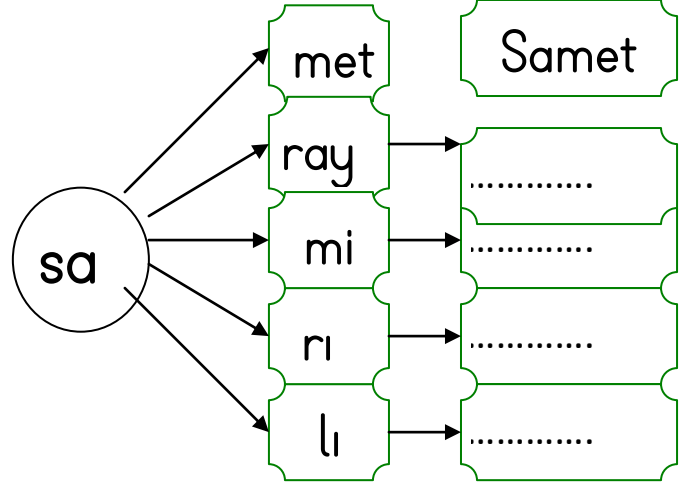
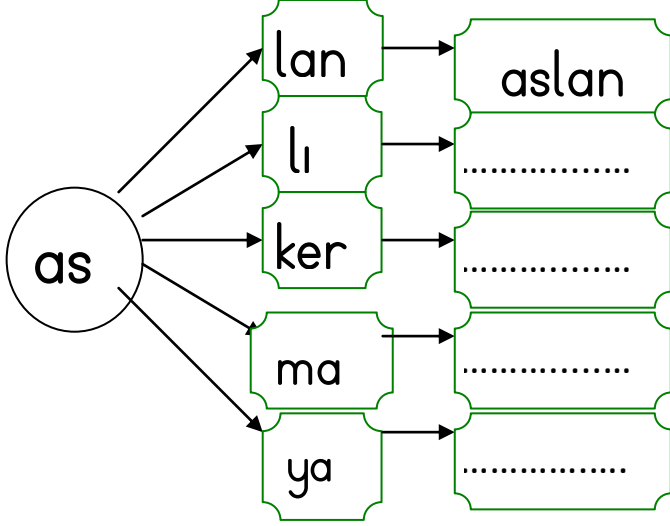

Oluşan kelimeleri okuyarak karşlarına yazınız.

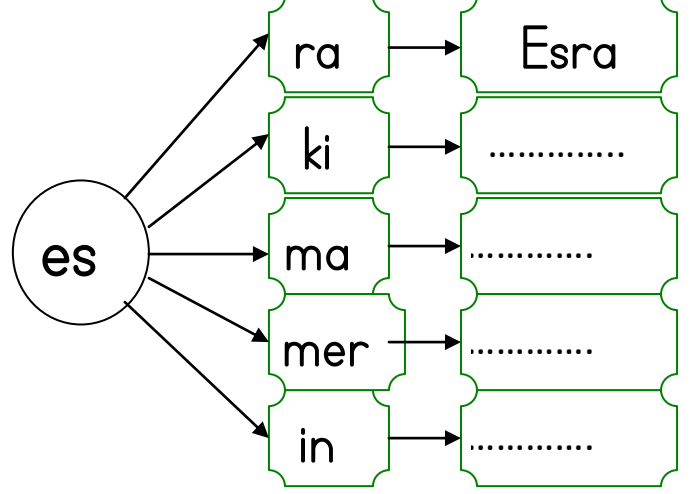
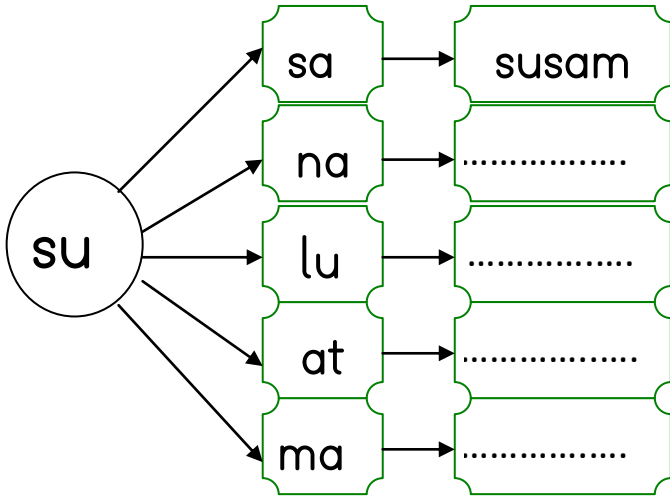

Aşağıdaki kelimeleri okuyarak karşlarına yazınız.

se	le	sele	ses	li	sesli	su	na
se	ne	sos	lu	su	ya
sa	na	soy	lu	su	yu
sa	lı	sus	tu	su	lu

Metni bol bol oku, Annen söylesin sen bakmadan defterine yaz.

Sat

Sema sarı elma sat.
Elmalar sulu sulu olsun.
Onları sık sık sula.
Suyunu eksik etme.

Sultan iki kilo elma al.
Onları rafa koy.
Selim elmayı kes kes ye.
Sakın elini kesme.

SIRA BİLDİREN SAYILAR

❖ Aşağıdaki görselle ilgili yönergeleri yapalım.



❖ Arıların çiçeğe yakınlığını numaralandırarak arıların altındaki kutuya yazalım.

- 1. arıyı sarı renge boyayalım.
- 2. arıyı turuncu renge boyayalım.
- 3. arıyı kahverengine boyayalım.
- 4. arıyı istediğimiz renge boyayalım.

❖ Aşağıdaki yarışta hangi yarışmacı 1. gelir yuvarlak içine alalım.

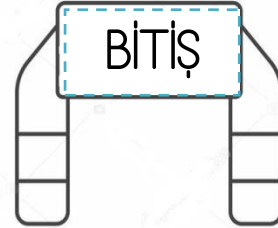

Aşağıdaki hayvanları büyükten küçüğe doğru numaralandırarak sıralayalım.

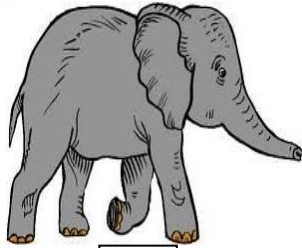

❖ Aşağıdaki tabloda boş bırakılan yerlere uygun sayıları yazalım, Sıralama işareti olan noktayı ekleyelim.

1.								9.	
	12.						18.		

❖ Aşağıdaki trende verilmeyen vagonların sırasını yazalım. Yazan yönergeleri yapalım.

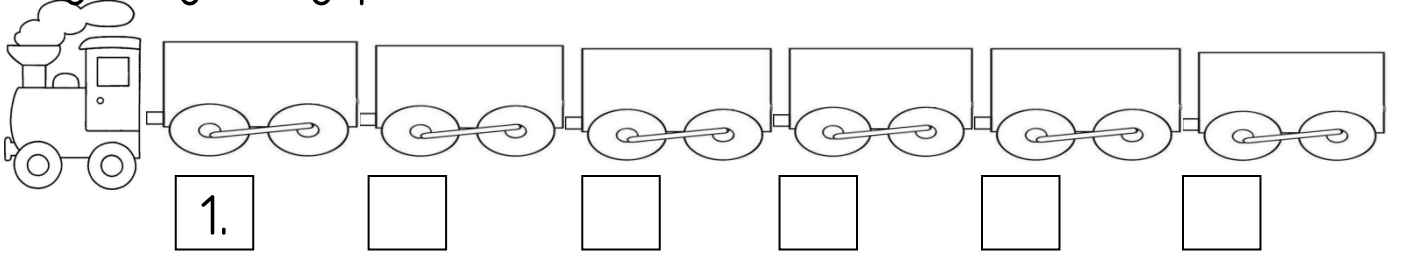

- * 1.vagonu mor renge boyayalım.
- * 2. vagonu yeşil renge boyayalım.
- * 3.vagonu turuncu renge boyayalım.
- * 4.vagonu kırmızı renge boyayalım.
- * 5.vagonu sarı renge boyayalım.
- * 6.vagonu mavi renge boyayalım.

❖ Kim hangi evde oturuyor? Altlarına yazalım.



1.



2.



3.



4.

--	--	--	--



5.



6.



7.



8.

--	--	--	--

3.Ali

8.Emir

5.Leman

2.Umut

1.Tuna

4.Öykü

6.Ayla

7.Melek