

Heceleri çok okuyalım. Bakmadan yazalım.

el	al	il	ol	ul	le	la	li	lo	lu
ek	ak	ik	ok	uk	ke	ka	ki	ko	ku
en	an	in	on	un	ne	na	ni	no	nu
em	em	im	om	um	me	ma	mi	mo	mu

Aşağıda verilen birleştirmelere dikkat edelim.

o ku ko ku mu m ku m

.....

ku le o nu ko nu kuk la

.....

Nu man ku lak lo kum

.....

Aşağıdaki cümleleri yardımsız okuyana kadar okutunuz ve defterine yazdırınız.

Nu man iki kilo lokum al.

Ali limonlu lokum al.

İki koli lokum al.

Kenan mum al.

Nu man  oku.

MUM

Okan mum al.

Okan mum al.

Okan onlu mum al.

Okan ona unlu mum al.

Okan ona onlu kokulu mum al.

Okan ona onlu mum al.

Okan onlu mum al.

Okan mum al.

KONUK

Nil konuk ol.

Nil komik konuk ol.

Nil iki komik konuk ol.

Nil kakaolu kek al.

KUKLA

İki kukla.

İki minik kukla.

İki minik kollu kukla.

İki minik komik kukla.

MİNE

Mine kokulu mum al.

Mine ona kokulu mum al.

Mine lokum ekle.

Limonlu nane ekle

Mine olumlu ol.

ONAR ONAR SAYALIM

Trenimizin vagonlarına eksik sayıları yazalım

10 20 30 40 50 60 70 80 90 100

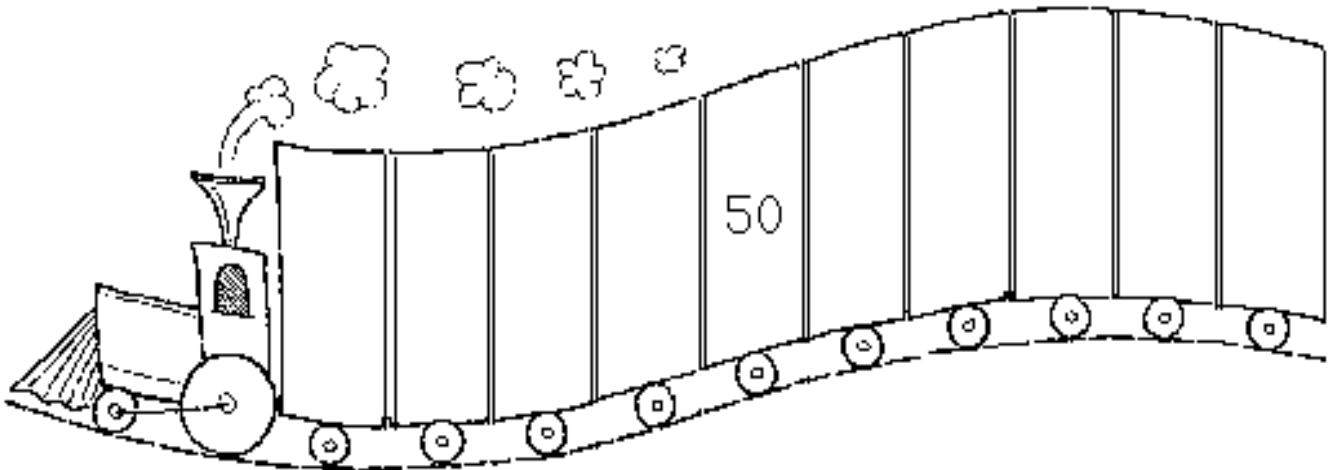
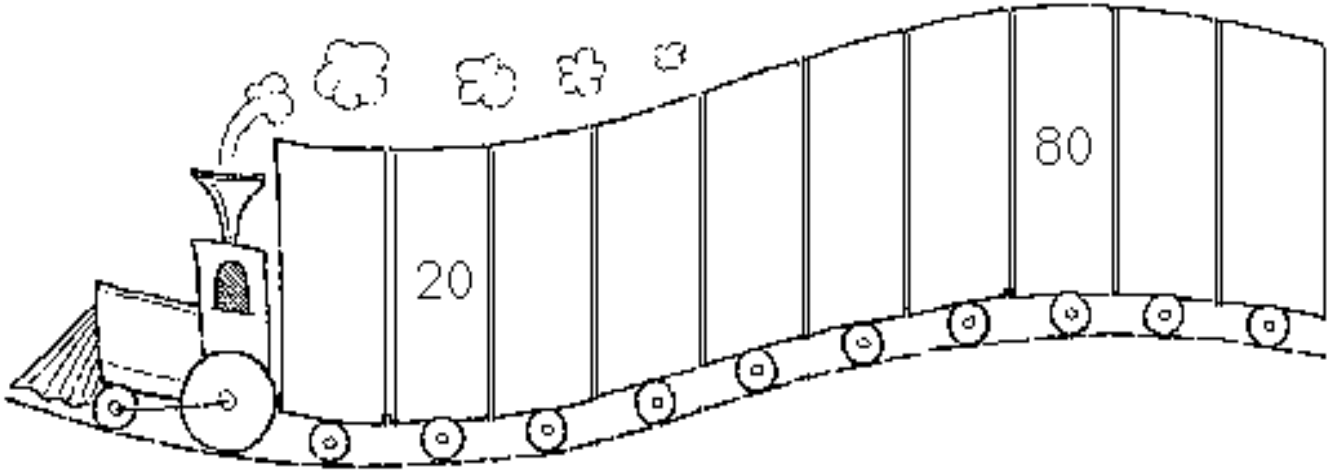
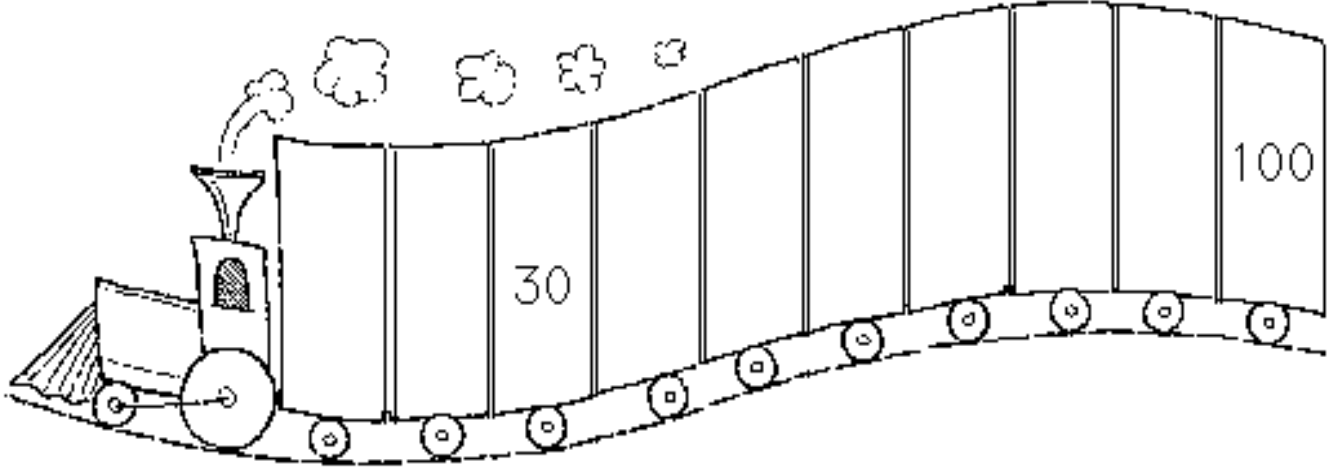

ONAR ONAR SAYALIM, YAZALIM

Aşağıdaki şekilleri onar onar sayıp altına yazınız.

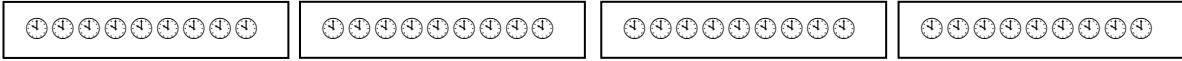
 → _____

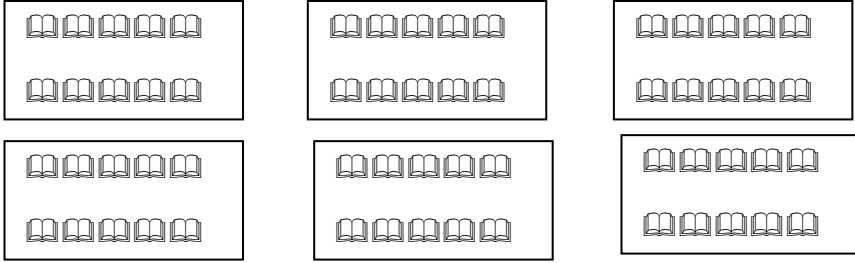
 → _____

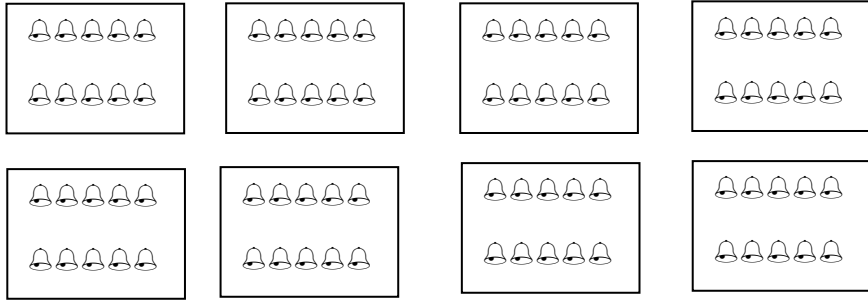
 → _____

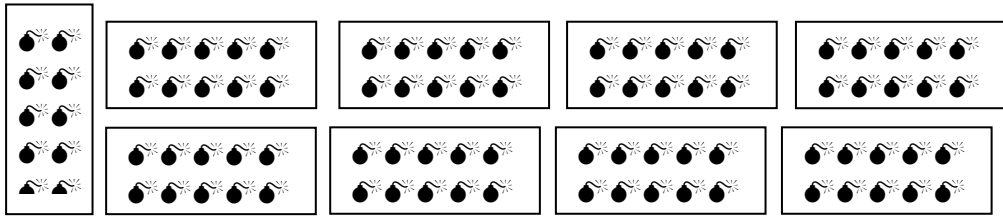
 → _____

 → _____

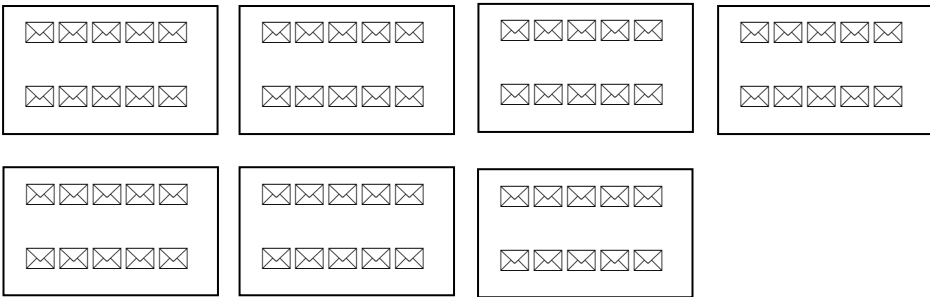
 → _____

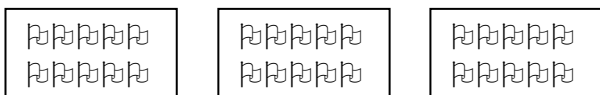
 → _____